



SWE150E



◆ High power engine

The engine of internationally famous brand is adopted, with large power reserve, strong power, high reliability and durability.

◆ Convenient maintenance

It is equipped with grease lubricated sealed track chain, which has long service life and is free from maintenance; 4 large filter elements are centrally arranged for easy maintenance and large maintenance space.

◆ Wider applicability

It can be optionally equipped with dozer blade and a variety of accessories, with wider applicability.

◆ Mature and reliable imported hydraulic system

Strong comprehensive operation ability and high efficiency

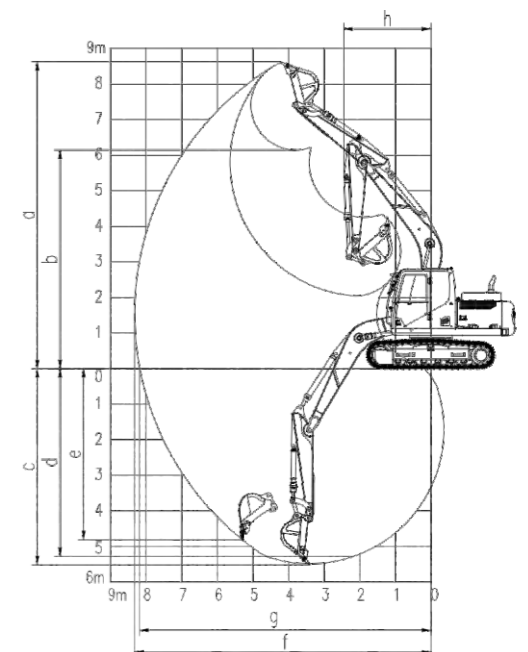
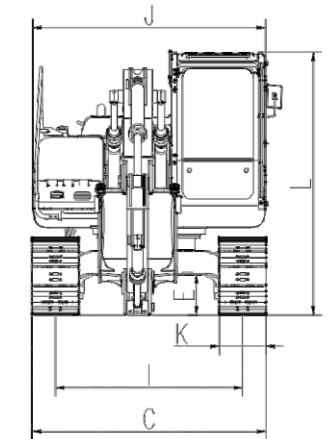
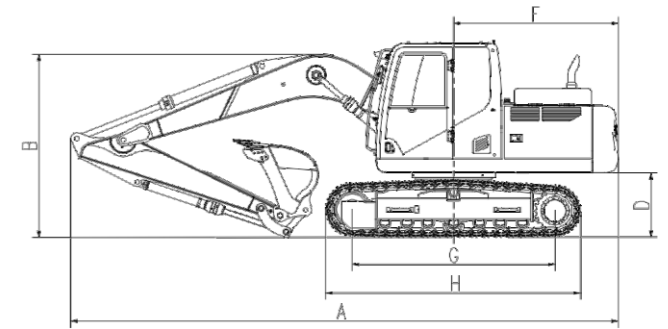

ENGINE		UNIT	SWE150E
Working weight		kg	14800
Capacity of bucket		m ³	0.6
Engine	Brand		ISUZU
	Type		GI-4JJIXKSC
	Rated output power	kW/rpm	86/2200
Dimension parameters	A Transportation length	mm	7840
	B Transportation height	mm	2850
	C Total width	mm	2500
	D Counterweight ground clearance	mm	940
	E Min. ground clearance	mm	410
	F Tail slewing radius	mm	2355
	G Ground contact length of track	mm	2915
	H Track length	mm	3650
	I Track gauge	mm	2000
	J Turntable width	mm	2490
	K Creeper tread width	mm	500
	L Cab height	mm	2850
Scope of work	a Maximum excavation height	mm	8640
	b Maximum dumping height	mm	6145
	c Maximum digging depth	mm	5525
	d Digging depth (2.44 m horizontally)	mm	5320
	e Maximum vertical digging depth	mm	4930
	f Maximum digging distance ground	mm	8330
	g Maximum digging distance on	mm	8185
	h Minimum front slewing radius	mm	2530
Swing arm length		mm	4600
Bucket arm length		mm	2500
Bucket arm digging force		kN	76
Bucket digging force		kN	100
Speed (high/low)		km/h	5.4/3.3
Slewing speed		rpm	11
Fuel tank capacity		L	245
Hydraulic fuel tank capacity		L	150